

The following procedure is a supplement to other documentation supplied with this equipment and will guide the user in properly wiring the A1000, motor and encoder. It will also show the user how to configure the A1000 in closed loop mode operation using a PG-X3 card for a dedicated applications.

**Danger: Improper wiring can and will cause bodily harm as well as damage to the equipment.**

When installing the system, be sure to follow good wiring practices and all applicable codes. Ensure that the mounting of components is secure and that the environment, such as extreme dampness, poor ventilation, etc. will not cause system degradation.

**Please read this cheat sheet and other documentation provided with the A1000 thoroughly before attempting any installation.**

## Step 1 A1000 Model Identification and Mounting

To make sure you received the correct model, it is essential to verify the A1000 nameplate with your order and make sure the A1000 has the correct rating so it can be used with your motor. Please check the nameplate information as shown in the example below.

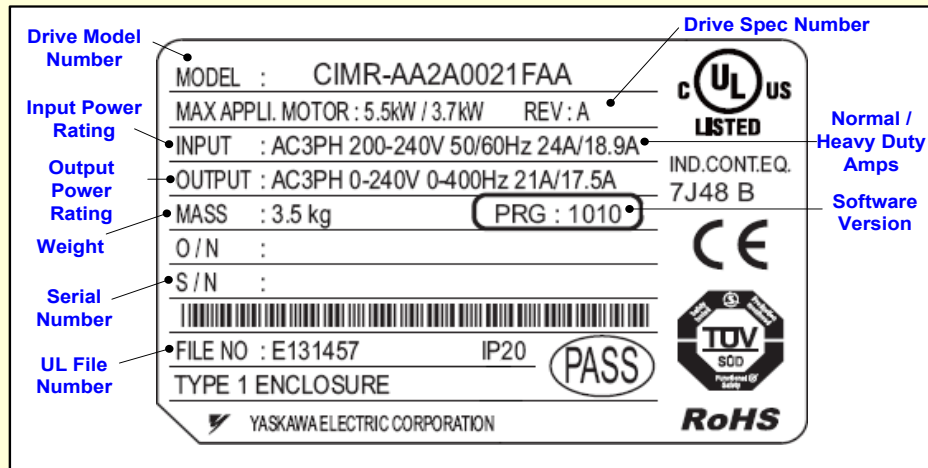

- Check that the available power will meet the **input power** requirements.
- Ensure that the **output power** from the A1000 is compatible with the motor requirements.
- In the case of systems with more than one A1000, follow the above procedure for each A1000 and motor.

### Mounting the A1000

The mounting of the A1000 is extremely important regarding environment and accessibility. Depending on your system, there are various models available and the mounting dimensions (footprint) may be different. Because the mounting procedure is fairly extensive, it is beyond the scope of this document; the user is referred to the A1000 User Manual (Document No. SIEP C710606 21A) received with the A1000, **Section 2.2 Mechanical Installation**. Match the model that you received and follow the procedure described in the manual to ensure a safe and functional installation. In cases where the system has more than one A1000, refer to the proper clearances required for adequate ventilation. *Please pay particular attention to:*

- The clearances to be maintained around the enclosure for adequate ventilation.
- The environmental specifications such as avoiding excessive dampness, extreme temperatures, chemical exposure, corrosive areas, etc. to avoid damage to the equipment and to maintain safety.

### Removing and Attaching the Terminal Cover

Improper removal of the A1000 terminal cover as well as front cover can cause extensive damage to the A1000. To avoid damage to these items, please pay particular attention to the A1000 User Manual, Document No. SIEP C710606 21A, Section 3.5, **Removing and Attaching the Terminal Cover**.

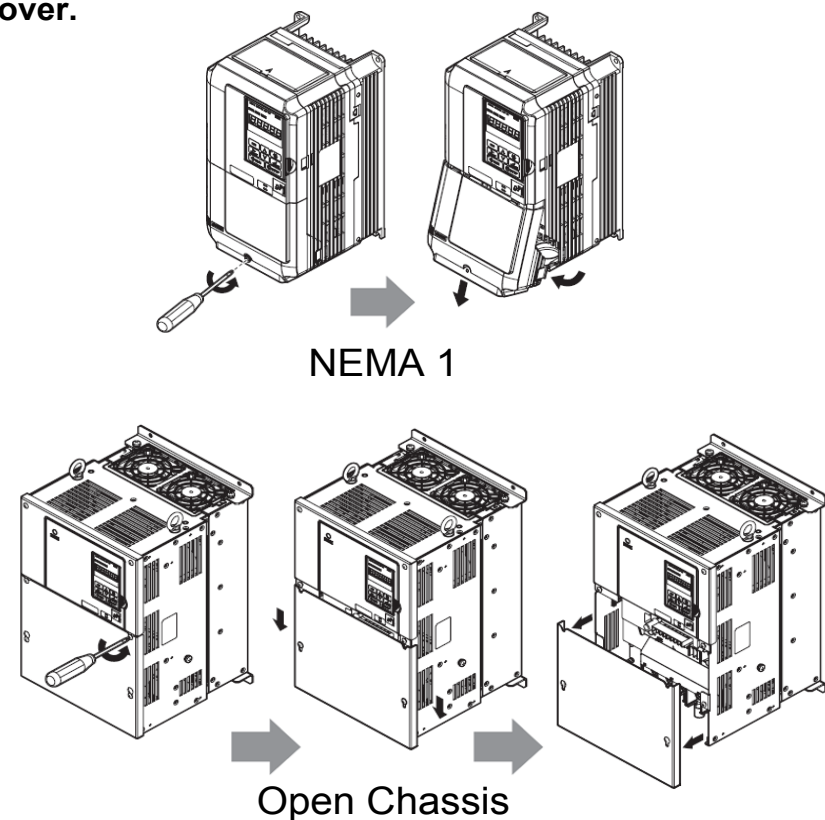

## Step 2 Connect Motor and Line Power

Fig.1 & 2 below show the electrical connections for the input power and motor terminals for various A1000 models. Select the proper diagram for the model you are installing (see Step 1). **WITH POWER OFF** make the appropriate connections. **Make sure to follow good wiring practices and all applicable codes. Ensure that the equipment is grounded properly as shown in fig. 1**

**DANGER; LETHAL VOLTAGES ARE PRESENT- Before applying power to the A1000, ensure that the terminal cover is fastened and all wiring connections are secure. After the power has been turned OFF, wait at least five minutes until the charge indicator extinguishes completely before touching any wiring, circuit boards or components.**

**WARNING DO NOT CONNECT ANY OF THE FOLLOWING TERMINALS TO EARTH GROUND**

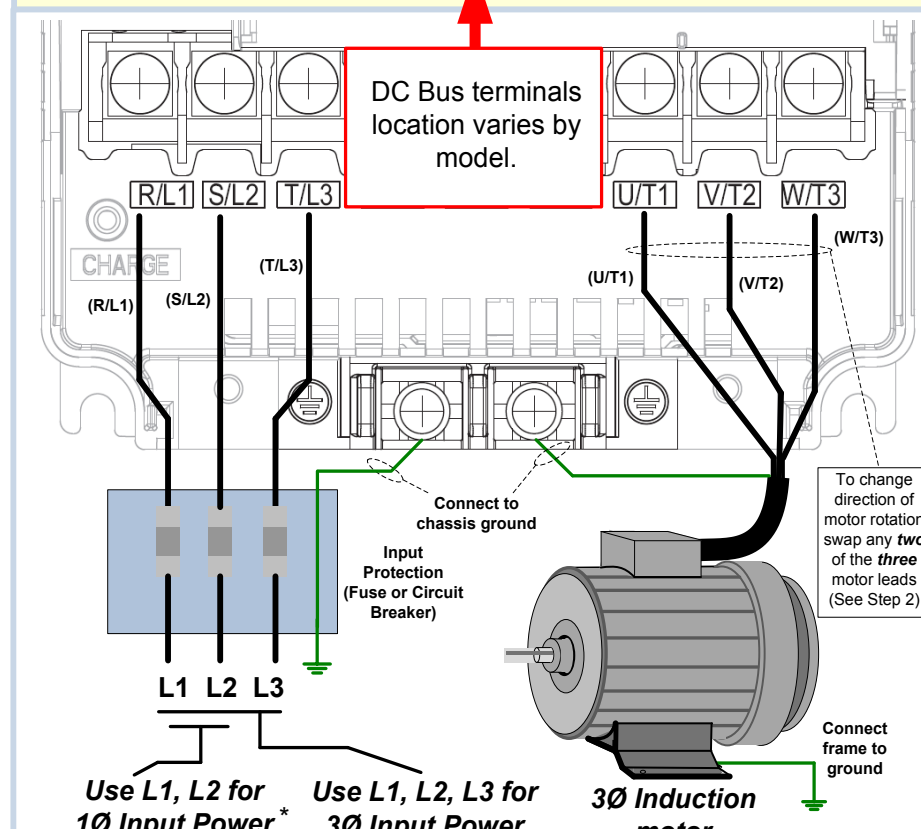
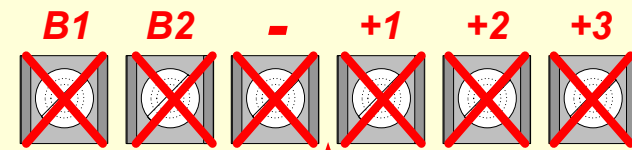

Fig. 1 Input Power and Output Motor Electrical Connections for Models: 2\_0004 - 2\_0056, 4\_0002 - 4\_0044 and 5\_0003 - 50011

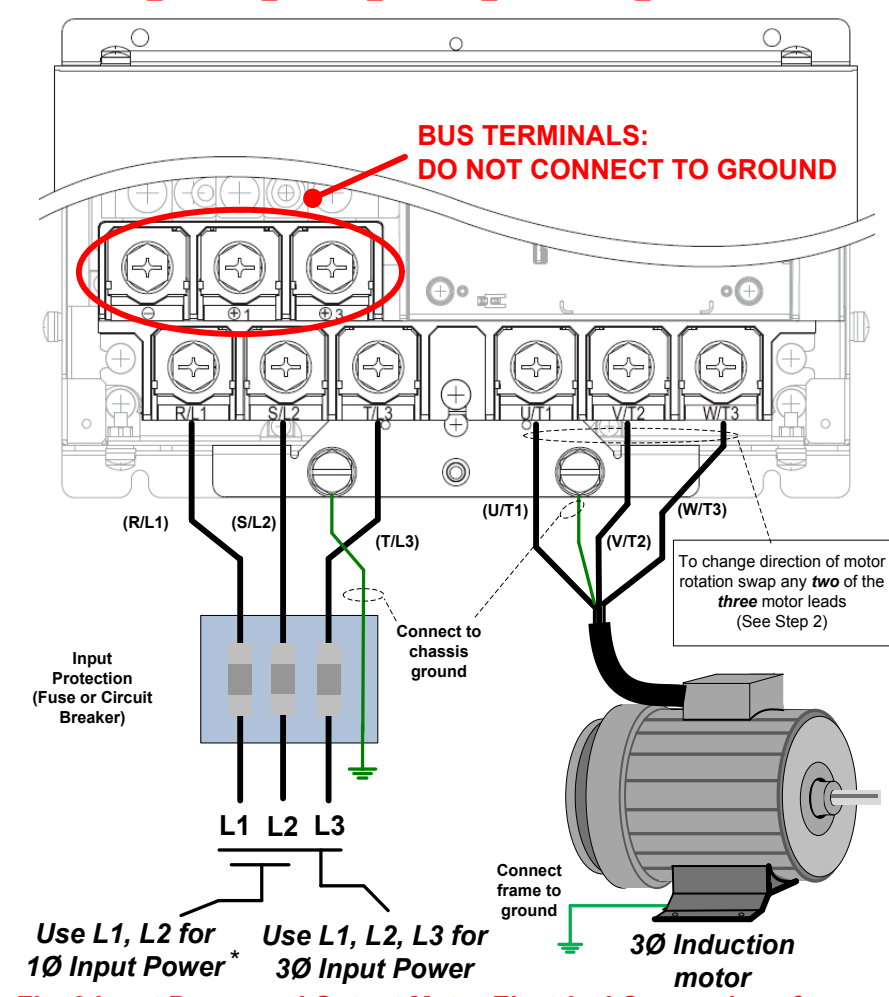

Fig. 2 Input Power and Output Motor Electrical Connections for Models: 2\_0110 & Larger and 4\_0058 & Larger

\* Make sure the A1000 has been properly sized for single phase input power. For best performance, the drive input supply voltage must be at least equal to or greater than the motor rated voltage.

## Step 3 Install PG-X3 Feedback Card and wire encoder feedback

In this step the PG-X3 encoder feedback card is installed. **WITH POWER OFF** install the PG-X3 card as shown below. **Make sure to follow good wiring practices and all applicable codes. Ensure that the feedback card is grounded properly as shown in fig. 3 item H.**

This option card can be inserted into either the CN5-B or CN5-C connectors located on the drive's control board. If only one option card is connected to the drive, use the CN5-C connector. If two option cards are connected, use both CN5-B and CN5-C. See the A1000 User Manual, Document No. SIEP C710606 21A, Section 3.5, for directions on removing the front cover.

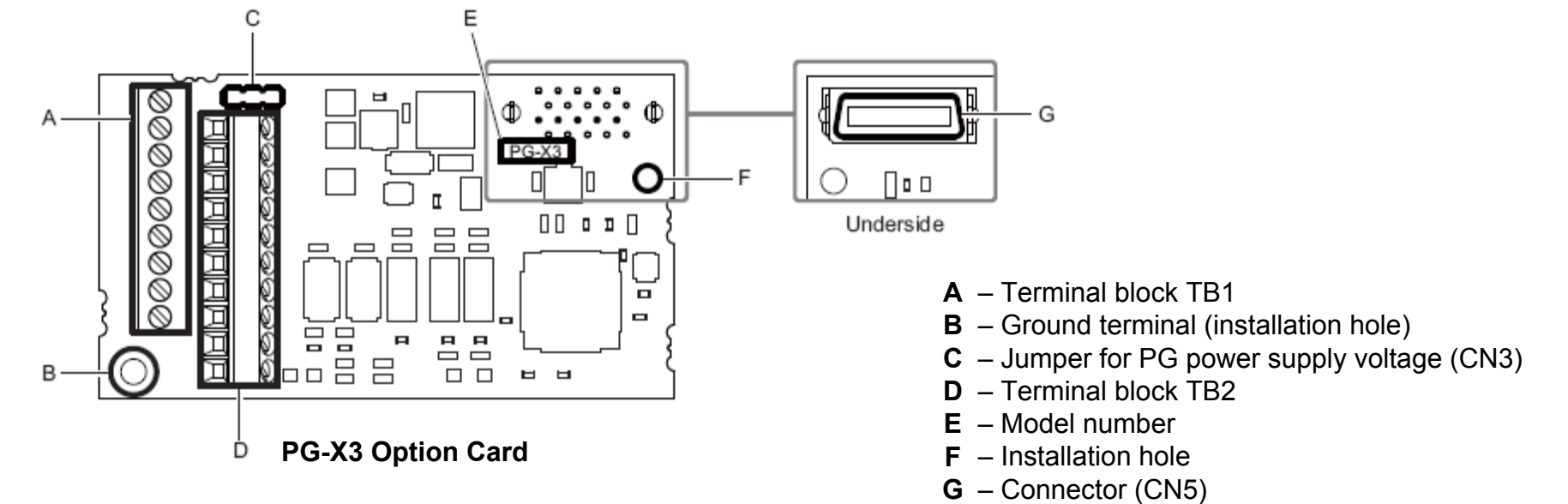

### Option Card Installation

Insert the PG-X3 card (connector CN5) into the matching CN5 connector on the A1000 control card. Next use the screws to fasten the card into place. Connect one of the ground lead lines to the ground terminal with one of the screws. Two separate ground lead lines have been included with the option card. Use the longer one when the option card is plugged into connector CN5-C on the A1000 control card side and use the shorter one if the PG-X3 card is plugged into connector CN5-B.

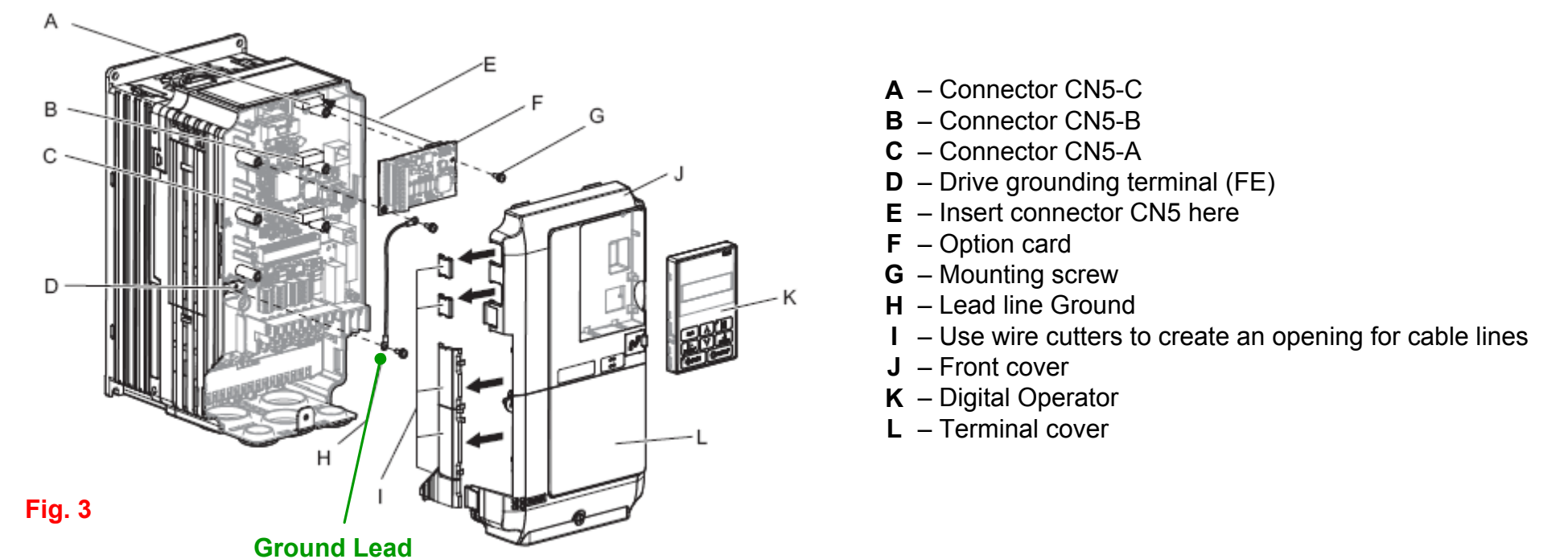
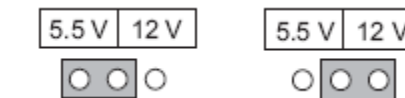

Fig. 3

### Encoder Power Supply (Max. 200mA)

Select Encoder Power Supply (IP + IG TB2) with Jumper CN3.



### Default

**IMPORTANT: Verify Encoder Power Supply Rating**

### Encoder Connection

**DANGER** A single channel encoder can only be used in V/f + PG control mode (A1-02 = 1). It is required to use a quadrature encoder in Flux Vector control mode (A1-02 = 3).

Connect Encoder (PG) signals to TB1 terminals of the PG-X3 card as shown below. Connect power supply from the PG-X3 card (TB1 – Terminals IP and IG) to the Encoder (PG).

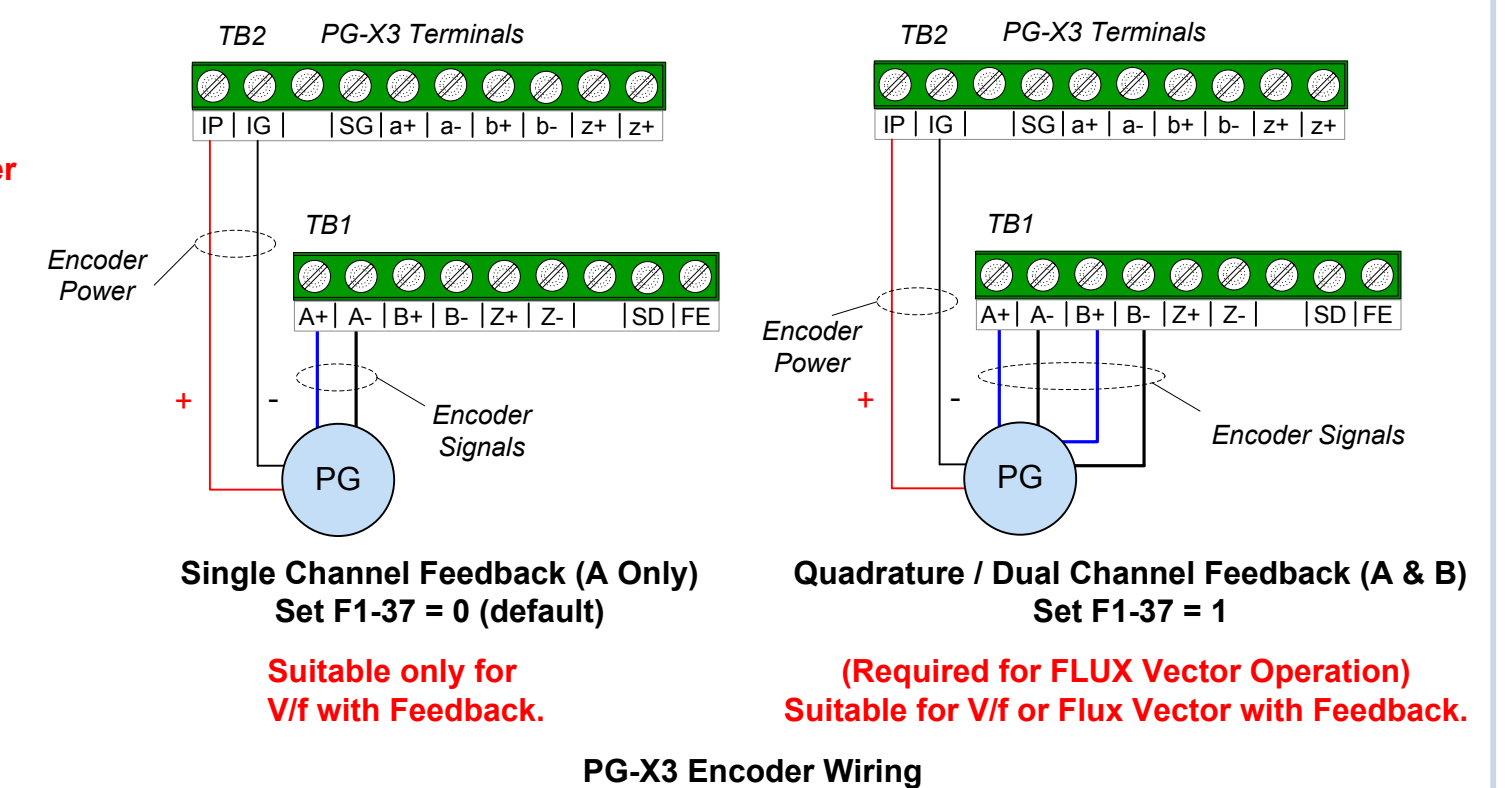

PG-X3 Encoder Wiring

## Step 4 Check Motor Rotation in Open Loop (Motor uncoupled from Load)

In this step the motor is checked for proper direction and operation. This test is to be performed solely from the digital operator. Apply power to the A1000 after all the electrical connections have been made and protective covers have been re-attached. At this point, **DO NOT RUN THE MOTOR**, the Digital Operator should display as shown in **Fig. 3**.

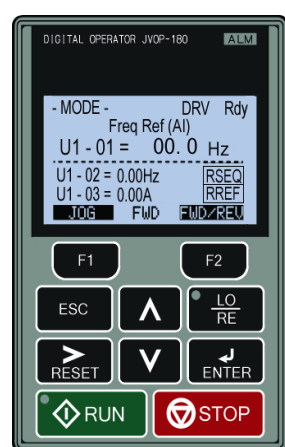

**Fig. 3**  
Digital Operator

### Motor Rotation Test

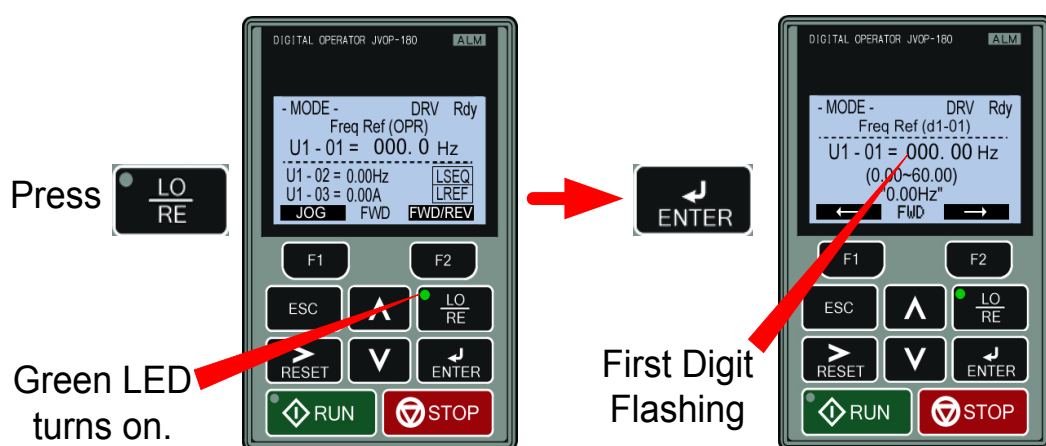

Next, press **RESET** to move the cursor one position to the right and **↑** to increase the frequency reference (d1-01) to 10.00 Hz.  
Press **ENTER** to save frequency reference.

10.00 Hz

Next, press **RUN** on the Digital Operator. The motor should now be operating at low speed running in the correct forward (clockwise) direction.  
Next, press **STOP** on the Digital Operator.

**If motor rotation is not correct, then either reverse "Phase Order" using parameter b1-14 or power down the drive, wait five minutes and swap 2 motor leads.**

### ⚠ DANGER

**After the power has been turned OFF, wait at least five minutes until the charge indicator extinguishes completely before touching any wiring, circuit boards or components.**

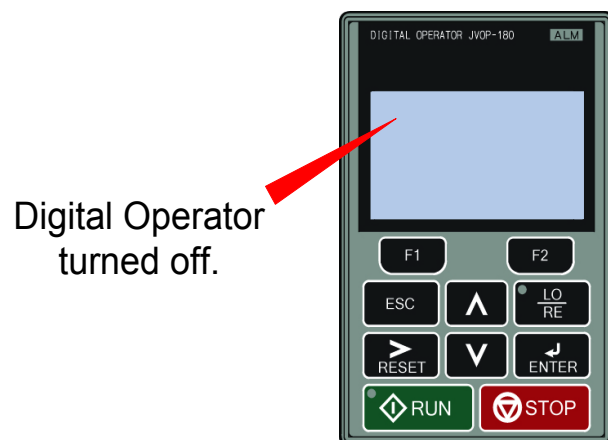

Use precaution, and refer to **Fig.1 or 2**, swap any **two** of the **three** output leads to the motor (U/T1, V/T2 and W/T3). After the wiring change, repeat **Step 3** and recheck motor direction.

## Step 5 Changing Parameters and Monitoring the A1000

This step shows how to access and modify a A1000 parameter as well as how to monitor A1000 signals such as output frequency and motor current.

Make sure all protective covers have been re-attached and power is turned on. **DO NOT RUN THE MOTOR.**

### Access Parameter Menu and Change Parameter Value

Press **↓** two times until the digital operator shows the parameter menu.

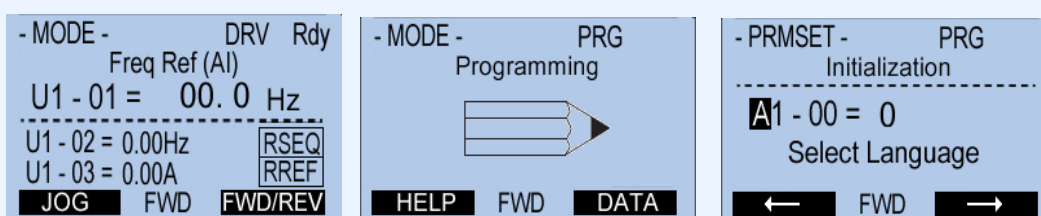

2X **↓** → **ENTER** → **RESET**  
Select Digit



**↑** **↓** → **RESET** → **2X** → **↑** **↓**  
Inc./Dec. Selection      Go to Next Digit      Inc./Dec. Selection

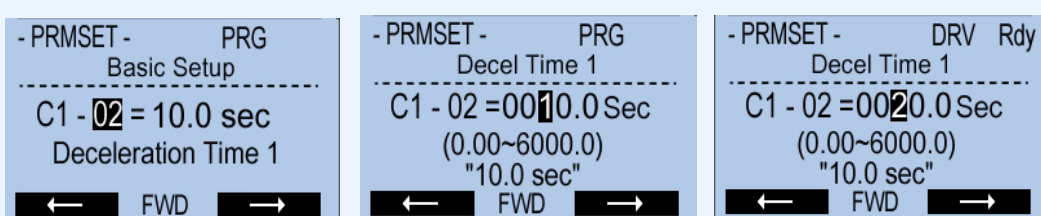

**ENTER** → **↑** **↓** → **ENTER**  
Switch to Edit Mode      Modify Value      Save New Value

### Monitor Motor Frequency and Motor Current

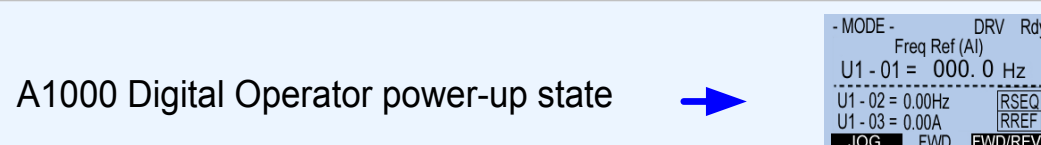

Output Frequency and Motor Current can be monitored simultaneously.

To monitor output frequency and motor current or other signals

individually, press **↑** once, the press **ENTER**

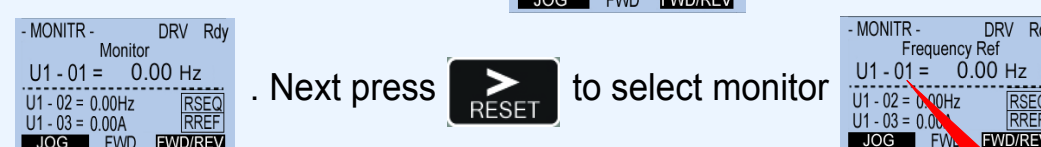

Next press **RESET** to select monitor  
Use **↑** **↓** to select monitor signal.      Digits Flashing

U1-02 Output Frequency

Please refer to the A1000 User Manual, (Document No. SIEP C710606 21A) on how to access other drive monitors.

## Step 6 Rotational Auto-Tuning Closed Loop (De-couple Motor from Load)

In this step the A1000 is setup for use with the motor in closed loop operation. Make sure the following has been done:

- Encoder (PG) connected correctly to the PG-X3 Card
- All protective covers have been re-attached
- Ensure the motor can spin freely and any connected mechanical brake is released
- Connected machinery should be allowed to rotate the motor

### IMPORTANT:

To achieve optimal drive performance use rotational Auto-Tuning with the load decoupled from the motor. If motor and load can not be decoupled, reduce the motor load so that it is no greater than 30% of the rated load. Performing rotational Auto-Tuning with a higher load can result in incorrect motor parameters and may cause irregular motor rotation.

Next apply power to the A1000. **DO NOT RUN THE MOTOR.**

### Select Closed Loop Control Method

A1-02

Select Closed Loop Control Method

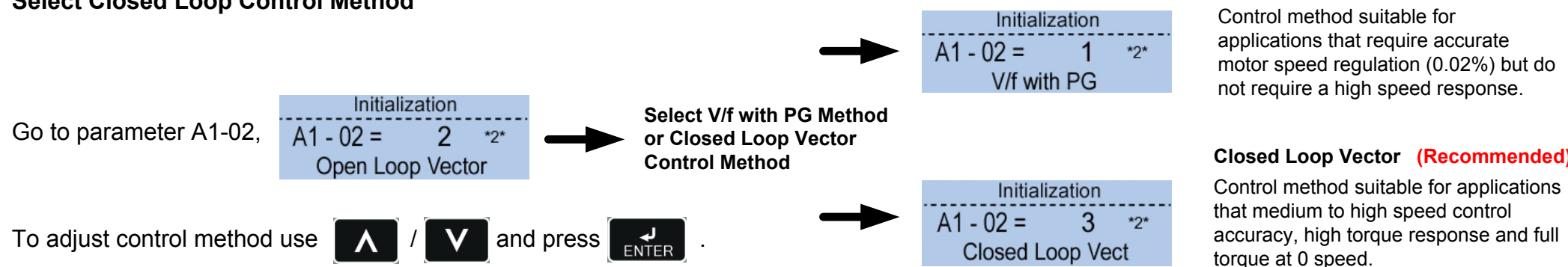

**Encoder Direction** → Check the motor speed monitor U1-05 while turning the motor manually in forward direction (CW). If the sign displayed is negative, power down the drive, **wait at least five minutes until the charge indicator extinguishes completely** then swap encoder wires A+ with A- on the PG-X3 card. Next power-up the drive and repeat this test. Or reverse the encoder direction with parameter F1-05. For encoders with only A & B outputs, exchange A & B.

### Auto-tuning Procedure

#### Start here

From the main reference press **↓** once until the Digital Operator shows the Auto-Tuning menu then press **ENTER**



Press **↑** once until the Digital Operator shows parameter T1-02 Mtr Rated Power then press **ENTER**  
**Enter Motor Power in kW (Kilowatt)**

Motor HP to kW = HP x 0.746  
Example: 10HP = 10 x 0.746 = 7.46 kW

Digit Flashing

Press **RESET** to select the digit you would like to change and use **↑** **↓** adjust value and press **ENTER** to save.

Press **↑** to select the next parameter and follow the same procedure described above to adjust its value.

Continue →

- T1-03 Rated Voltage (e.g. 230 V, 460 V)
- T1-04 Rated current (e.g. 11.0 A, 22.0 A)
- T1-05 Rated Frequency (e.g. 60.0 Hz)
- T1-06 Number of Poles (e.g. 4 Poles)
- T1-07 Rated Speed (e.g. 1750 rpm)
- T1-08 Encoder / PG Number of Pulses per Rev. (e.g. 1024)

**For standard AC motors use the default setting for motor base frequency (60Hz), motor poles (4) and motor rated speed.**

After setting parameter T1-08 press **↑** to select the Auto-Tuning start command.

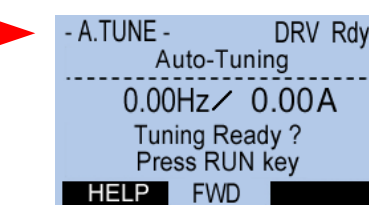

**Warning! Sudden movement hazard. The A1000 and motor may start unexpectedly during Auto-Tuning.**

**Warning! Electric Shock Hazard. High voltage will be supplied to the motor when stationary Auto-Tuning is performed. Do not touch the motor during auto-tuning.**

**Notice: Auto-Tuning will not function properly when a brake is engaged on the load. Ensure the motor shaft can freely rotate. Never perform an Auto-Tune with motor connected to a load.**

Next, press **RUN** on the Digital Operator. The A1000 will now start the Auto-tuning procedure.

The display will show message "**Tune Successful**" when the Auto-Tuning procedure has been successfully completed.

Please refer to the A1000 User Manual or repeat the procedure again if the display shows an error message.

## Step 7 Selecting Start/Stop and Speed Reference Sources

This step shows how to setup the run and reference source of the A1000. The run source determines how the A1000 drive receives its start and stop command and the reference source determines how the speed of the motor is controlled. Make sure all protective covers have been re-attached and power is turned on. **DO NOT RUN THE MOTOR.**

*This section may require you to change one or more A1000 parameters. Please refer to Step 5 for a detailed explanation on how to change parameters.*

### SELECT REFERENCE SOURCE b1-01

#### 1. Adjust motor speed / frequency from the Digital Operator

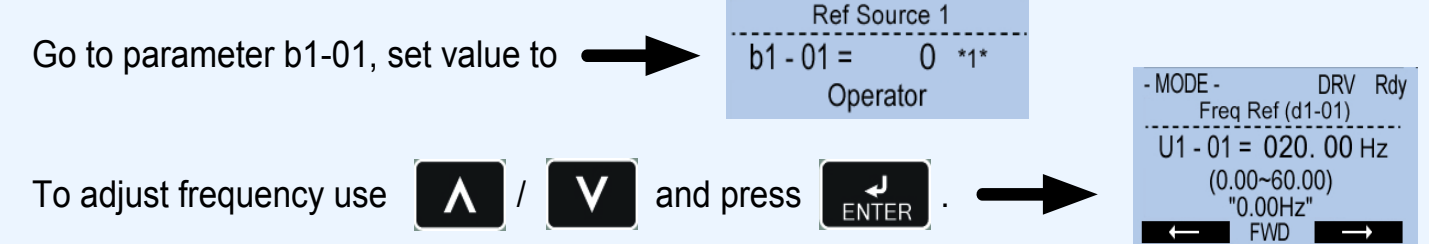

#### 2. Adjust motor speed / frequency from external terminals (0 - 10V / 4 - 20mA Signal)

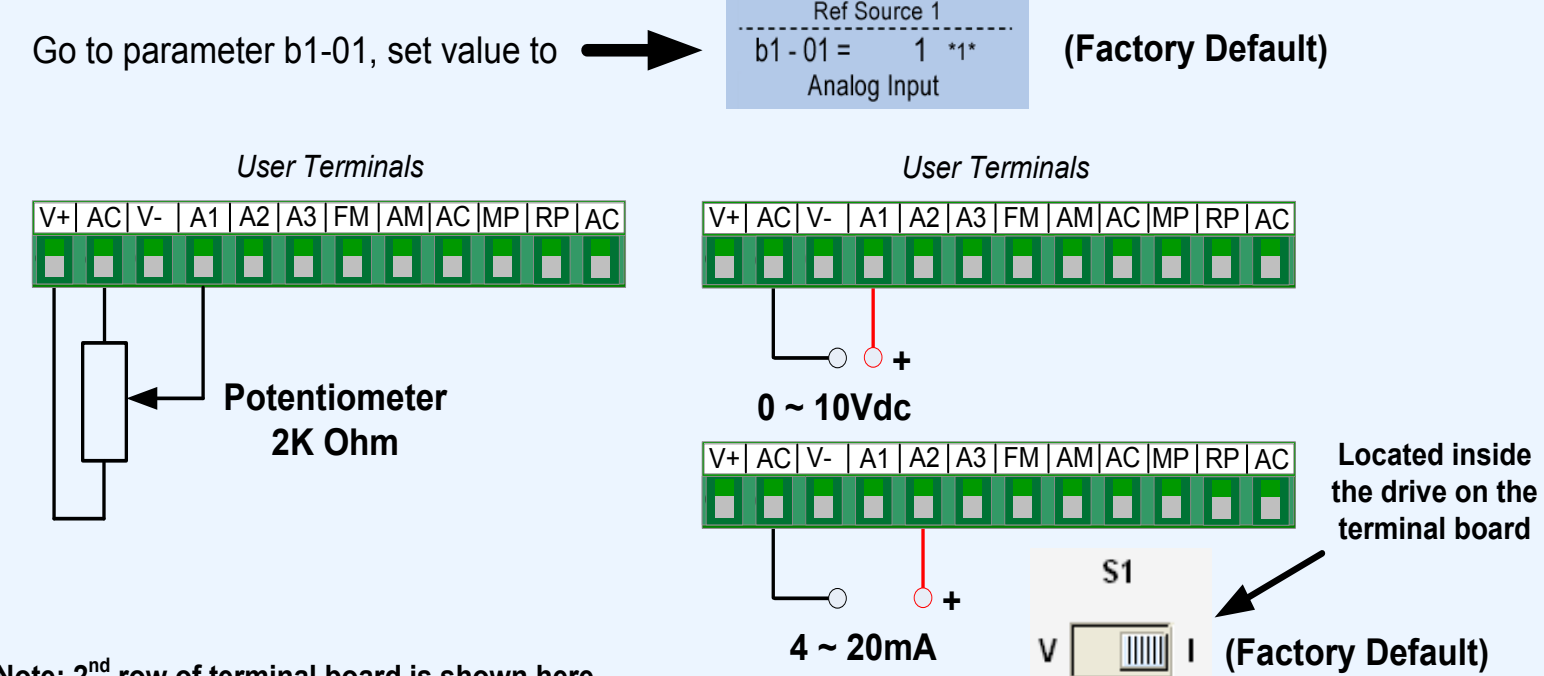

Note: 2<sup>nd</sup> row of terminal board is shown here.

### SELECT RUN SOURCE b1-02

#### 1. Start / Stop Control from Digital Operator

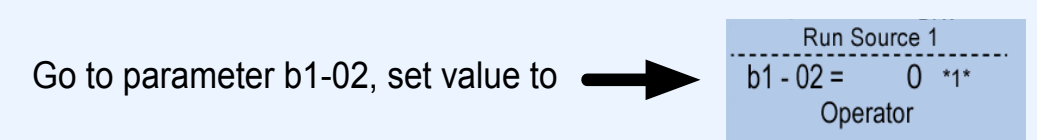

#### 2. Start / Stop Control from external terminals (switch or relay contact)

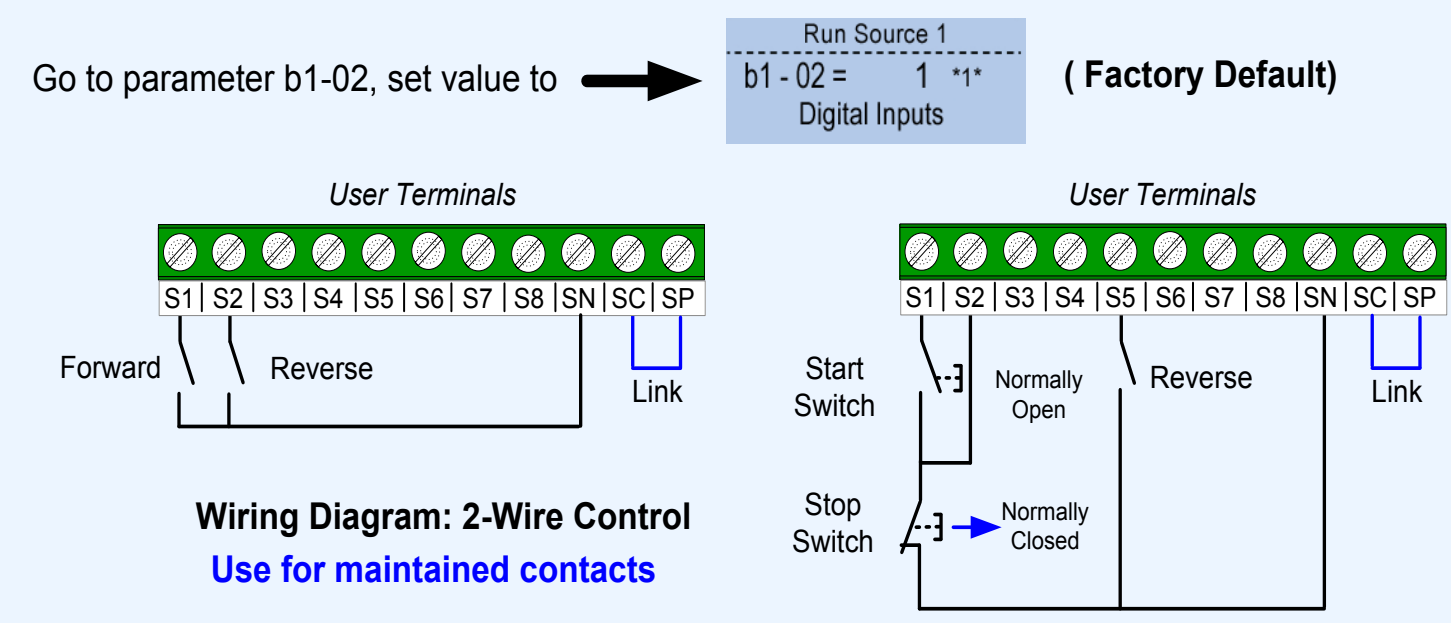

Note: 3<sup>rd</sup> row of terminal board is shown here.

NOTE: It is beyond the scope of this document to program the A1000 drive for network communication control. Please refer to the refer to the A1000 User Manual, (Document No. SIEP C710606 21A) for this selection.

## Step 8 Motor Performance Fine Tuning

The following tables show how to fine tune motor operation for V/f with PG and Closed Loop Vector Operation. Please refer to the A1000 User Manual (Document No. SIEP C710606 21A) for additional information.

### V/f Control with encoder feedback (A1-02 = 1)

Problem	Parameter	Action	Default	Suggested Setting
• Motor is hunting and oscillation at speeds between 10 and 40Hz.	n1-02 Hunting Prevention Gain	<ul style="list-style-type: none"> <li>If insufficient motor torque relative to the size of the load causes hunting reduce the setting.</li> <li>When motor hunting and oscillation occur with a light load increase setting.</li> <li>Lower this setting if hunting occurs when using a motor with a relatively low inductance such as a high-frequency motor or a motor with a larger frame size.</li> </ul>	1.00	0.10 to 2.00
• Motor noise • Motor hunting and oscillation at speed up to 40Hz	C6-02 Carrier Frequency Selection	<ul style="list-style-type: none"> <li>If the motor noise is too loud increase the carrier frequency.</li> <li>When motor hunting and oscillation occur at speeds up to 40 Hz lower the carrier frequency.</li> <li>The default setting for the carrier frequency depends on the drive capacity (o2-04) and the Duty Selection (C6-01).</li> </ul>	1 (2 kHz)	1 to max. setting
• Poor torque or speed response • Motor hunting and oscillation	C4-02 Torque Compensation Primary Delay Time	<ul style="list-style-type: none"> <li>If motor torque and speed response are too slow, decrease the setting.</li> <li>If motor hunting and oscillation occur, increase the setting.</li> </ul>	200 ms <1>	100 to 1000 ms
• Poor motor torque at speeds below 10 Hz • Motor hunting and oscillation	C4-01 Torque Compensation Gain	<ul style="list-style-type: none"> <li>If motor torque is insufficient at speeds below 10 Hz, increase the setting.</li> <li>if motor hunting and oscillation with a relatively light load, decrease the setting.</li> </ul>	1.00	0.50 to 1.50
• Poor motor torque at low speeds • Motor instability at motor start	E1-08 Mid Output Voltage A E1-10 Minimum Output Voltage	<ul style="list-style-type: none"> <li>If motor torque is insufficient at speeds below 10 Hz, increase the setting.</li> <li>If motor instability occurs at motor start, decrease the setting.</li> </ul> <p><b>Note:</b> The recommended setting value shown is for 200 V class drives. Multiply value x 2 for 400V class drives and x 2.875 for 575V class drives.</p>	E1-08: 15.0 V <2> E1-10: 9.0 V <2>	Default setting ±5 V
• Poor speed precision	C5-01 ASR Proportional Gain 1 <3> C5-02 ASR Integral Time 1 <4>	Adjust the ASR proportional gain 1 (C5-01) and the ASR integral time 1 (C5-02).	C5-01: 0.20 C5-02: 0.200	Prop. gain = 0.10 to 1.00 Int. time = 0.100 to 2.000

### Closed Loop Vector Control (A1-02 = 3)

Problem	Parameter	Action	Default	Suggested Setting
• Poor torque or speed response • Motor hunting and oscillation	C5-01 ASR Proportional Gain 1 <4> C5-03 ASR Proportional Gain 1 <4>	<ul style="list-style-type: none"> <li>If motor torque and speed response are too slow, gradually increase the ASR gain setting by 5.</li> <li>If motor hunting and oscillation occur, decrease the setting.</li> <li>Parameter C5-03 needs to be adjusted only if C5-07 &gt; 0.</li> <li>Perform ASR Auto-Tuning if possible</li> </ul>	20.00	10.00 to 50.00
• Trouble maintaining the ASR proportional gain or the integral time at the low or high end of the speed range	C5-02 ASR Integral Time 1 <4> C5-04 ASR Integral Time 2 <4>	<ul style="list-style-type: none"> <li>If motor torque and speed response are too slow, decrease the setting.</li> <li>If motor hunting and oscillation occur, increase the setting.</li> <li>Parameter C5-04 needs to be adjusted only if C5-07 &gt; 0.</li> </ul>	0.500 s	0.300 to 1.000 s
• Motor hunting and oscillation	C5-07 ASR Gain Switching Frequency <4>	Have the drive switch between two different ASR proportional gain and integral time settings based on the output frequency.	0.0 Hz	0.0 to max. freq. output
• Motor noise • Motor hunting and oscillation occurs at speeds below 3 Hz	C5-06 ASR Primary Delay Time Constant <4>	<ul style="list-style-type: none"> <li>If motor torque and speed response are too slow, gradually decrease the setting by 0.01.</li> <li>If the load is less rigid and subject to oscillation, increase this setting.</li> </ul>	0.004 s	0.004 to 0.020s
• Overshoot or undershoot when the speed changes with high inertia load	C6-02 Carrier Frequency Selection  Use S-Curve: C2-01, C2-02, C2-03, C2-04	<ul style="list-style-type: none"> <li>If there is too much motor noise, the carrier frequency is too low.</li> <li>If motor hunting and oscillation occur at low speeds, reduce the carrier frequency.</li> </ul> <p>Note: The default setting for the carrier frequency depends on the drive capacity (o2-04) and Drive Duty Selection (C6-01).</p>	1	2KHz to max. setting
			0	1

<1> Default setting value is dependent on parameter A1-02, Control Method Selection, and o2-04, Drive Model Selection.  
 <2> Default settings change when the Control Method is changed (A1-02) or a different V/f pattern is selected using parameter E1-03.  
 <3> ASR in V/f Control with PG only controls the output frequency, and therefore does not allow for high gain settings like in Close Loop Vector control.  
 <4> Refer to C5: Automatic Speed Regulator (ASR) in the A1000 User Manual (Document No. SIEP C710606 21A) for details on Automatic Speed Regulator (ASR).